

TB175W

OPERATING RANGE

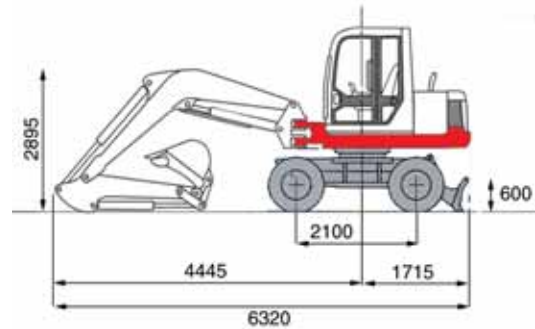

In accordance with our established policy of constant improvement, we reserve the right to amend these specifications at any time without notice. Photographs shown may feature non-standard equipment.

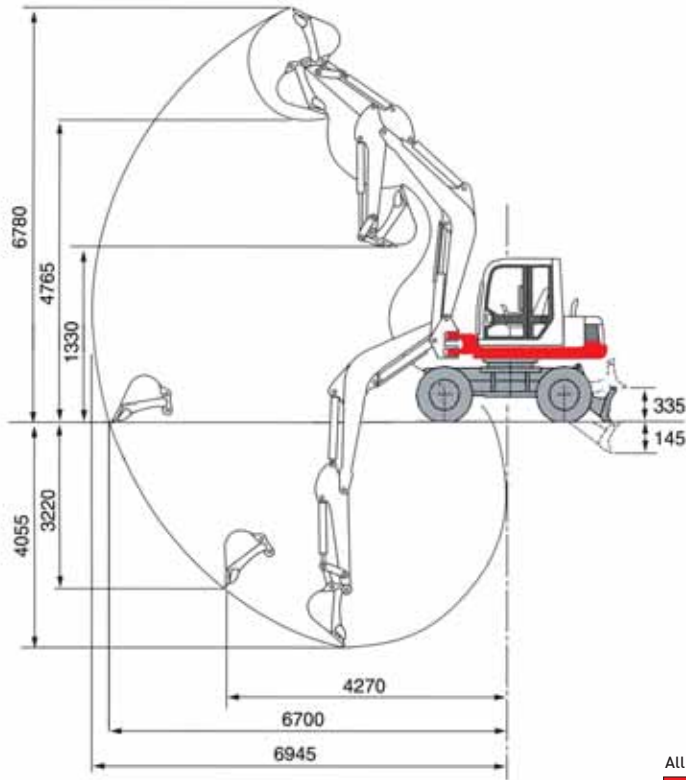
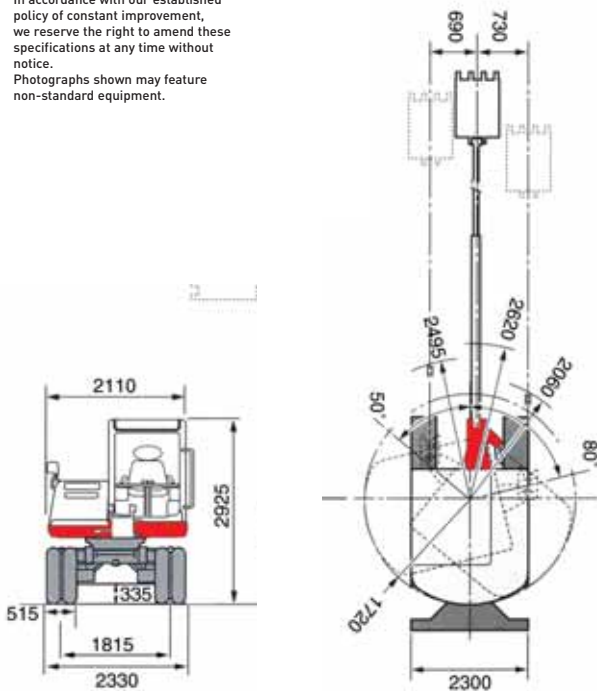

All Dimensions unless otherwise stated are in millimeters

DIMENSIONS & WEIGHT		OPERATING INFORMATION	
Operating Weight (kg)	7905	Max. Dig Depth	4055
Length (transport)	6320	Max. Dump Height	4765
Width	2330	Max. reach at ground level	6700
Height	2925	Max. Vertical Dig Depth	3220
Ground Clearance	335	Max. Bucket Dig Force (Kn)	52.7
Min front swing radius (80° boom swing)	2060	Max. Arm Dig Force (Kn)	36
Tail swing radius	1720	UNDERCARRIAGE	
Dozer Blade (wxh)	2300x600	Tyre Size	8.25-20-12PR
ENGINE		Drive Line	All Wheel Drive
Make/Model	Yanmar4TNE98-TBW	Travel Brake	Disc & Brake Lock
Rated Output/RPM	50kW/2300	Steering	Front Setting System
Maximum Torque	235Nm	Wheelbase	2100
Cylinders/Displacement	4/3318cc	Tyre Pressure (psi)	85
Electrical System	24volt 40amp	Travel Speed (K/ph)	30
SWING SYSTEM		Maximum Gradeability	35°
Boom Swing angle (L/R)	80°/50°	HYDRAULIC SYSTEM	
Slew Speed (rpm)	4.1/10.7	Set Pressure (bar)	280
Slew Motor	Axial Piston	Pump Type	Variable(P1+P2)+Gear(P3+P4)
Slew Brake	Disc	Hydraulic Flow (l/min)	69x2+53.6+20.7
CAPACITIES (l)		Auxiliary Flow (l/min)	69
		Hydraulic system	132
		Fuel tank	120
		Engine Lubrication	10.2
		Cooling System	9.5

TAKEUCHI

Takeuchi Mfg (UK) Ltd, Lynroyle Way, Rochdale, Lancs OL11 3EX Tel: 01706 657722 Fax: 01706 657744

e-mail: sales@takeuchi-mfg.co.uk www.takeuchi-mfg.co.uk

Southern Office at Thatcham, Newbury Tel: 01635 877 196 Fax: 01635 877 195

TB175W

FULLY HYDRAULIC COMPACT EXCAVATOR



TAKEUCHI

TAKEUCHI

THE HIGHLY TB175W WHEEL



**SUPERB
OPERATOR
COMFORT**



VERSATILE WHEELED EXCAVATOR

Take the TB175 tracked compact excavator and fit it with wheels and you get our TB175W.

What you also get is a versatile self propelled wheeled excavator weighing in at 7905kg.

Powered by a low noise powerful diesel engine of 50Kw. the TB175W has a top speed of 30kph - so it can drive between jobs quickly and efficiently, ideal for urban highways or recycling tasks.

The isolation cab, incorporating a heater, AM/FM radio etc. makes operator comfort a priority and coupled with legendary Japanese precision build quality the TB175W has the built in reliability & performance that are a Takeuchi trade mark.

EASY ENGINE ACCESS AND MAINTENANCE



FEATURES

- Wide angle independent boom swing
- Three hinged ground level access covers
- Cast iron wrap around protective counterweight
- Standard dozer blade
- Steel engine cover
- Spring applied, hydraulically released disc type slew brake
- Two front work lights and side mounted swing lights
- Isolation mounted cab with heater, demister, windscreen wiper and washer, AM/FM cassette radio and retractable front window with removable lower section

PERFORMANCE

- Proportional control auxiliary hydraulics
- Two speed travel
- Simultaneous operation of cab swing and digging functions with no reduction in working speed
- Automatic arm and boom hoist acceleration
- Servo assisted hand and foot operated controls
- Two speed cab rotation

OPERATION

- Adjustable steering column
- Axle lock cylinders
- Two-way auxiliary hydraulics plumbed to dipper arm
- Electronically controlled engine speed with three operating modes
- Pilot operated joystick controls with armrests
- Sliding operators station with fully adjustable suspension seat and head rest

SAFETY & SERVICE

- Electronic engine monitoring with emergency shutdown/return-to-idle system
- Automatic fuel bleed system
- Remote slew lubrication system
- Vandalism protected lockable fuel tank and engine compartment
- Hydraulic oil cooler
- Engine oil 'Safedrain' system
- 2 Year Warranty

OPTIONS

- TKB301 Hydraulic Breaker
- Auger
- QuickHitch