

# WTS6203 Wash Plant

## TTH6203 Screen & TTSW3625 FMW



### Standard Features

#### TTH6203 Horizontal Screen

Triple shaft, oval stroke design  
Forged steel shaft precision machined for eccentricity  
Forged alloy steel, aircraft quality crowned tooth gears  
Controlled splash-type oil lubrication system with baffles  
Flow through bearing drive hubs; oil bath lubrication  
Adjustable oval stroke amplitudes, speed and angle  
Huck bolt construction  
30 KW drive 1000 rpm

#### TTSW3625 Fine Material Washer

Cast ni-hard shoes  
Adjustable overflow weirs  
2 x 11 KW Drives  
Rising current manifold with 4" inlet  
1-1/2" Chase water inlet (2)  
Grease lubricated lower bearings  
Extreme duty large reduction gearboxes

### Chassis

Triple axle, to CE, TUV specification  
Mud flaps, brakes and lights.  
Fifth wheel kingpin  
Ladder and service platforms  
Cribbing supports  
Blocking points

### Side Discharge Conveyors for 2nd and 3rd Decks

V-belt drive with guard  
5" C conveyor idlers

### EUROPE

TRIO Equipment Europe Ltd.,  
Clonminam Industrial Park,  
Portlaoise, Co. Laois,  
Ireland.  
Telephone: +353 (0) 57 8661333  
Fax: +353 (0) 57 8672550  
Email: sales@trioeurope.com  
Web: www.trioeurope.com

### UNITED STATES

Trio Engineered Products, Inc.  
12823 Schabaram Avenue  
Irwindale, CA 91706  
Telephone: +1 626 851 3966  
Fax: +1 626 851 9526  
Email: info@trioproducts.com  
Web: www.trioproducts.com

# WTS6203 Wash Plant

## TTH6203 Screen & TTSW3625 FMW

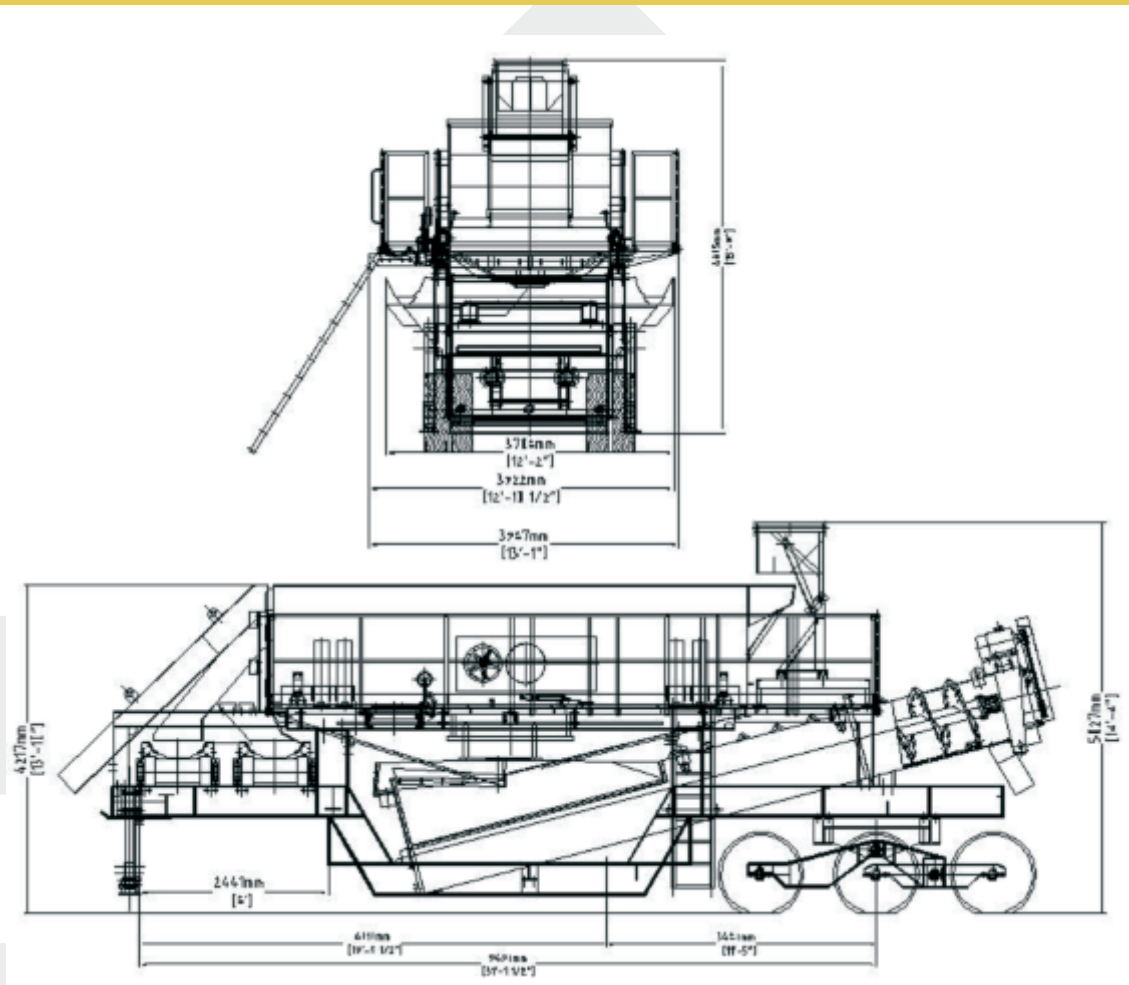

### Specifications

Horizontal Screen.....1800mm x 6000mm  
Operating Speed.....675-875 rpm

Fine Material Washer.....36" x 25' x 2  
Operating Speed.....5-21 rpm  
Capacity.....up to 300 TPH

### Horsepower

Screen.....30 KW  
Screw.....2 x 11 KW

### Weights and Dimensions

#### Travel

Length.....12 Mtrs  
Height.....4.2 Mtrs  
Width.....3.85 Mtrs  
Kingpin Height.....1.2 Mtrs

#### Estimated Weights

Total.....32272 kg  
Rear.....20454 kg  
Kingpin.....11818 kg

EUROPE  
TRIO Equipment Europe Ltd.,  
Clonminam Industrial Park,  
Portlaoise, Co. Laois,  
Ireland.  
Telephone: +353 (0) 57 8661333  
Fax: +353 (0) 57 8672550  
Email: sales@trioeurope.com  
Web: www.trioeurope.com

### Distributed by:

UNITED STATES  
Trio Engineered Products, Inc.  
12823 Schabarum Avenue  
Irwindale, CA 91706  
Telephone: +1 626 851 3966  
Fax: +1 626 851 9526  
Email: info@trioproducts.com  
Web: www.trioproducts.com